

SURGEEx-S

Stainless Steel Bellows Water Hammer Arresters



The SURGEEx-S series is a pre-charged, all stainless steel, bellows type water hammer arrester that provides excellent surge pressure absorption. SURGEEx-S arrester is available in sizes AA through F with end connection ranging from 1/2" to 1". The SURGEEx-S has a hermetically sealed air cushion that eliminates air loss, ensuring consistent performance. The unit is fabricated from high-grade stainless steel to withstand chemical degradation and attack from waterborne contaminants.

OPERATION

SURGEEx-S series water hammer arresters use stainless-steel bellows as the main component to absorb the shock waves caused by water hammer. When a water hammer occurs, the bellows compresses as water rushes into the arrester, creating a cushioning effect that absorbs the pressure surge. As the water flow slows down and pressure stabilizes, the bellows returns to its original position, ready to absorb the next water hammer.

FEATURES

- Fabricated entirely from Stainless steel grade 304 to provide excellent resistance against common waterborne chemicals and ensure durability.
- Designed for easy installation with no access panel required, reducing installation time and cost.
- Suitable for use in new or existing residential, commercial and industrial plumbing systems with a standard pipe tee.
- Factory pre-charged and hermetically sealed, eliminating the need to charge it after installation and ensuring reliable performance.
- Sized according to international standards, ensuring proper operation and protection against water hammer.
- Available in both NPT and BSP threaded male end connections.
- Pre-Charged with Nitrogen for optimal performance and durability.

MATERIALS OF CONSTRUCTION

- Shell: Stainless Steel 304
- Bellows: Stainless Steel 304

WORKING PARAMETERS

- Pressure range: Up to 400 PSIG (27.6 BAR)
- Temperature: -100°F to 300°F (-73°C to 149°C)

STANDARDS

- Compliant with the latest American and Australian Standards
- Compliant with PDI WH-201 standards and requirements

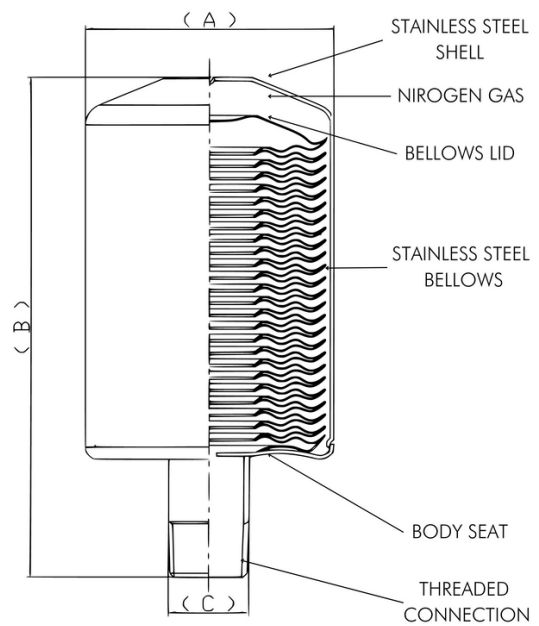
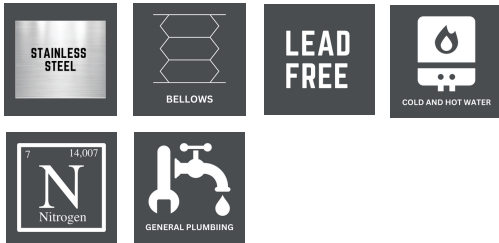

MODEL		S15-AA	S15-A	S20-A	S25-B	S25-C	S25-D	S25-E	S25-F
SIZE		AA	A	A	B	C	D	E	F
FIXTURE UNIT		1-4	5-11	5-11	12-32	33-60	61-113	114-154	155-330
DIAMETER (A)	INCH	2-13/16"	3-1/4"	3-1/4"	3-1/4"	3-1/4"	3-1/4"	3-1/4"	3-1/4"
	MM	71	83	83	83	83	83	83	83
HEIGHT (B)	INCH	3-3/8"	3-1/4"	3-1/4"	4-1/16"	4-3/8"	5-1/4"	7"	7"
	MM	86	83	83	103	111	133	178	178
CONNECTON (C)	INCH	1/2"	1/2"	3/4"	1"	1"	1"	1"	1"
	MM	15	15	20	25	25	25	25	25

Due to continuous improvement of the products, specifications including design, construction, materials, or dimensions might be modified without prior notice with no obligations to apply such modifications on sold products. Dimensions listed are approximate and for guidance only. Accurate measurements can be obtained or confirmed from Fluidex technical support.